



Solar Ready Installation Requirements

Developed by Energy Trust of Oregon

Table of Contents

| | | |
|----------|--|----------|
| 1 | Purpose | 2 |
| 2 | General | 2 |
| 3 | Solar Access & System Location..... | 2 |
| 4 | Solar Water Heating | 4 |
| 5 | Solar Electric | 4 |

Purpose

Planning ahead for the installation of a solar water heating or solar electric system by creating a residence that is “solar ready” can be a significant benefit to future homeowners. This Solar Ready Installation Requirements document details the requirements and minimum criteria for solar electric and solar water heating components installed by builders or solar trade allies through the Energy Trust New Homes program.

The purpose of these installation requirements is to ensure that preliminary work done to make a home solar ready is in compliance with Energy Trust’s full solar Installation Requirements, and will result in an easier and less costly installation of solar in the future. As a result, these specifications may differ from those of a manufacturer or exceed applicable codes.

Any variations from these Solar Ready Installation Requirements must receive prior approval from Energy Trust.

General

- 1.1 Installation site shall be grid or natural gas-connected and installed on real property in Oregon that receives either a) electrical service directly from Portland General Electric or Pacific Power, or, for homes with natural gas water heating, b) natural gas service from NW Natural or Cascade Natural Gas.
- 1.2 The installation shall be of industry standard and workmanlike quality.
- 1.3 Equipment installers shall be licensed according to the Oregon Building Codes Division and shall be working for a contractor that is licensed according to the Oregon Construction and Contractors Board.
- 1.4 Dissimilar metals that have galvanic action (such as aluminum and steel) shall be isolated from one another using industry standard practices (such as brass unions or nipples, non-conductive shims, washers, or other methods).
- 1.5 Aluminum shall not be placed in direct contact with concrete materials.
- 1.6 All installed system components shall be new.
- 1.7 All components shall be mounted securely.
- 1.8 Equipment shall not be modified such that it voids the listing or manufacturer warranty.

Solar Access & System Location

- 1.9 Proposed future location on the roof of the solar modules or collectors (“System Location”) shall be included in the plan set or documented with a roof diagram that accurately describes the following: See Figure 1 below.
 - Area reserved for the solar electric (photovoltaic or “PV”) array or solar water heating collectors;
 - Location of the pre-installed conduit and/or plumbing;
 - Set-backs from eaves or peaks, as required by code.

- 1.10 Solar resource at the System Location shall be measured with an Energy Trust sun chart or approved shading analysis tool as described on the Energy Trust [trade ally sun chart web page](#)¹. The solar resource will be used to determine if the installation meets the Tier 1 or Tier 2 requirements below and may be used to determine the incentive amount.
- 1.11 For Tier 1 installations, there shall be no less than 80% Total Solar Resource Fraction at the System Location, as verified by an Energy Trust sun chart or approved shading analysis tool.
- 1.12 For Tier 2 installations, there shall be 75-80% Total Solar Resource Fraction at the System Location, as verified by an Energy Trust sun chart or approved shading analysis tool.
- 1.13 System Location shall be free from all obstructions that would interfere with the placement of collectors or panels, including, but not limited to, chimneys, plumbing stacks, skylights, roof vents, gables, nearby overhangs, tree plantings and future home construction.
- 1.14 To allow for local requirements for firefighter roof access pathways, designated System Location shall be set back at least 3 ft from roof edges and, 1 ft from ridges and roof valleys. When installed, the actual system may be located within this setback if allowed by code.

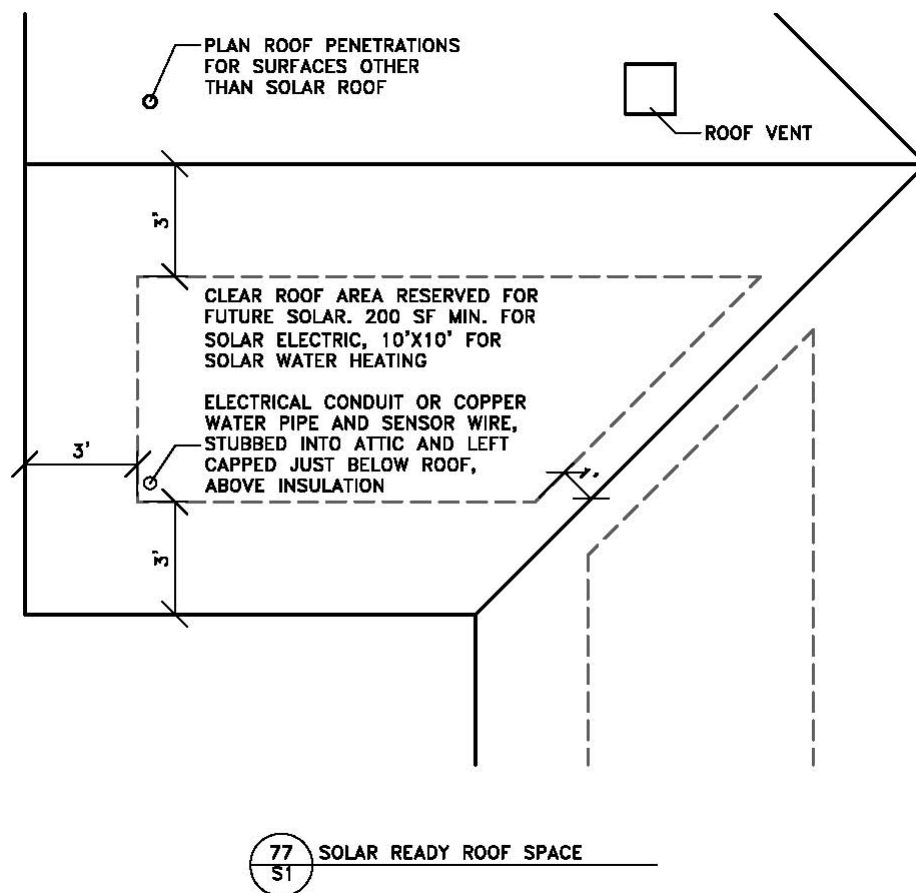

Figure 1. Sample Solar Roof Area Best Practices

¹ <http://energytrust.org/shared-resources/calculating-shading>. For more information, contact the Energy Trust New Homes solar specialist at 503-347-0541.

Solar Water Heating

- 1.15 A minimum of seventy square feet of un-shaded, obstruction-free roof space shall be reserved for the System Location, taking into consideration real dimensions of solar collectors.
- 1.16 A 32" x32" floor area with a height of 84" or more shall be reserved for an 80-gallon solar storage tank and controls next to the water heater.
- 1.17 ¾" supply and return rigid copper pipes shall be installed with a minimum slope of ¼" per foot from an accessible attic/roof area at the System Location to the space reserved for the solar storage tank. The terminating ends of these pipes shall be capped and labeled clearly, "For Solar Water Heater".
- 1.18 All plumbing lines shall be insulated with ¾" wall thickness insulation with a minimum temperature rating of 220°F.
- 1.19 Sensor wire shall be run parallel to the piping and attached securely to the outside of the insulation. Wire shall be long enough to reach System Location on roof and location designated for the storage tank inside. Leave wire coiled at each end and label, "Future Renewable Access".
Note: a ½" rigid or flexible conduit running parallel to the piping and terminating in junction boxes at both ends may also be used and would be necessary to accommodate a SWH system with a PV powered pump / control.
- 1.20 Plumbing lines with connections shall be pressure tested and free of leaks.
- 1.21 A sign or label shall be clearly posted on the standard water heater indicating that the home is "Solar Ready."

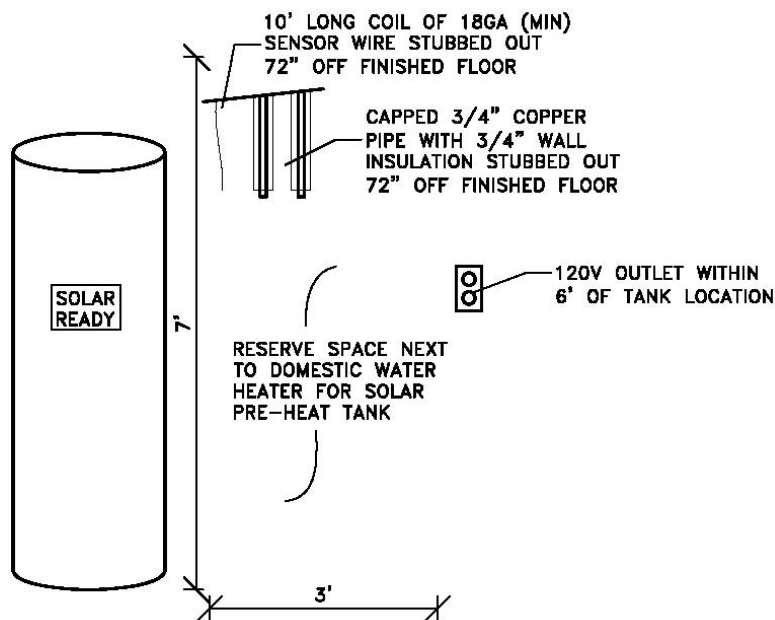

Figure 2. Solar Ready Best Practices for Solar Water Heating Systems

Solar Electric

- 1.22 A minimum of two-hundred square feet of un-shaded, obstruction-free roof space shall be reserved for the System Location, taking into consideration real dimensions of solar modules.
- 1.23 A 48" x 48" area of wall space near the electrical panel as possible shall be reserved for the future mounting of an inverter, meter and disconnect. If on the exterior of the house, this area must be protected from sun exposure.
- 1.24 All cables, conduit, and electrical boxes shall be secured and supported according to code requirements and in accordance with their performance ratings.
- 1.25 3/4" or larger rigid, steel conduit shall be installed from an accessible attic/roof area at the System Location to the space reserved for the inverter near the electrical panel. The terminating ends of this conduit shall be labeled clearly, "For Photovoltaics". At the inverter location the conduit shall be terminated in a 4" x 4" recessed metal box with a metal cover labeled clearly, "For Photovoltaics".
- 1.26 Electrical panels shall be sized to accommodate a minimum 40 A solar feed, and room shall be reserved for a double pole, 40 A 240 V breaker on the opposite end from the main service feeder for the future solar feed. The reserved breaker space shall be labeled "Reserved for Solar Feed."
- 1.27 A sign or label shall be clearly posted on or near the electrical panel indicating that the home is "Solar Ready."

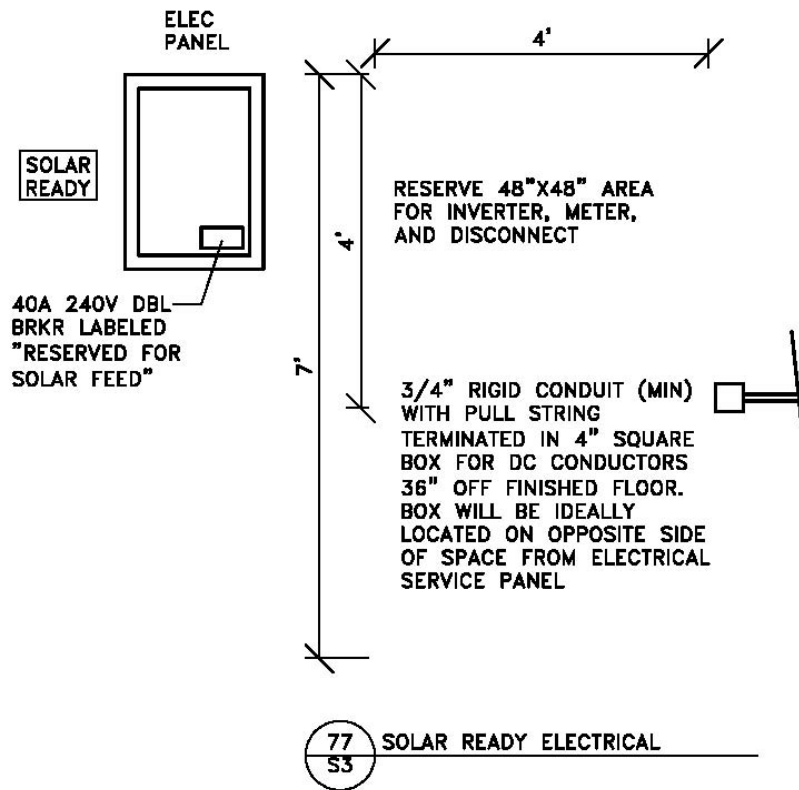

Figure 3. Solar Ready Best Practices for Photovoltaic Systems